

**KLT-USB-1170 V2****16MP 1170 Sony IMX298 M12 Fixed Focus USB 2.0 Camera Module**

KLT-USB-1170 V2 is a 16MP Fixed Focus USB camera module based on 1/2.8" IMX298 image sensor. It delivers high-speed, 4K resolution ultra sharp image. The S-mount (M12) lens holder enables customers to choose different lens as per varies applications. This camera module is ideal solution for face recognition, identity detection, access control.

Key Features

- 4K resolution (4656 x 3496) Sony IMX298 sensor
- High speed USB 2.0 Plug and Play
- MJPEG and YUV2 output format
- Low power consumption
- Compact size
- UVC compliant to Windows, Linux, OS with UVC driver
- USB OTG (On-The-Go) support

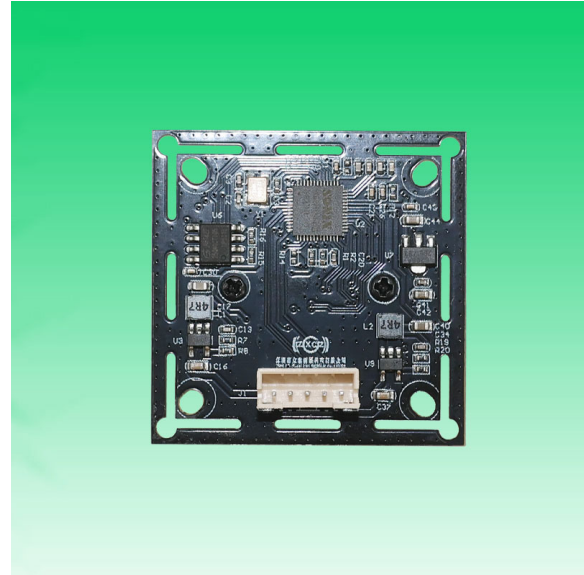

KLT-USB-1170 V2

16MP 1170 Sony IMX298 M12 Fixed Focus USB 2.0 Camera Module

| | |
|-------------------------|--|
| Camera Module No. | KLT-USB-1170 V2 |
| Resolution | 16MP |
| Image Sensor | IMX298 |
| Sensor Type | 1/2.8" |
| Pixel Size | 1.12 um x 1.12 um |
| EFL | 2.02 mm |
| F.NO | 2.50 |
| Pixel | 4656 x 3496 |
| View Angle | 119.8°(DFOV) 105.2°(HFOV) 87.2°(VFOV) |
| Lens Dimensions | 13.50 x 13.50 x 20.75 mm |
| Module Type | Fixed Focus |
| Interface | USB 2.0 |
| Output Format | MJPEG / YUV2 |
| Auto Control | Saturation, Contrast, Acutance White Balance, Exposure |
| Audio | Optional |
| Input Voltage | DC 5V |
| Working Current | Max 500mA |
| PCB Size | 38.00 x 38.00 mm / 32.00 x 32.00 mm |
| System Compatibility | Windows XP (SP2, SP3), Vista, 7, 8, 10, 11 Android, Mac OS, Linux or OS with UVC Driver Raspberry Pi by USB Port |
| Software for USB Camera | AMCAP, Webcam Viewer, V4L2 Controls Contacam, VLC Player, MotionEye OS iSpy, ZoneMider, Yawcam |
| Lens Type | 650nm IR Cut |
| Operating Temperature | -30°C to +85°C |
| USB Cable | USB Cable |

Wide Compatibility with Windows, Android, Mac OS, Linux, or Raspberry Pi



www.KaiLapTech.com sales@KaiLapTech.com Tel: (852) 6908 1256 Fax: (852) 3017 6778

**KLT-USB-1170 V2****16MP 1170 Sony IMX298 M12 Fixed Focus USB 2.0 Camera Module**

Top View

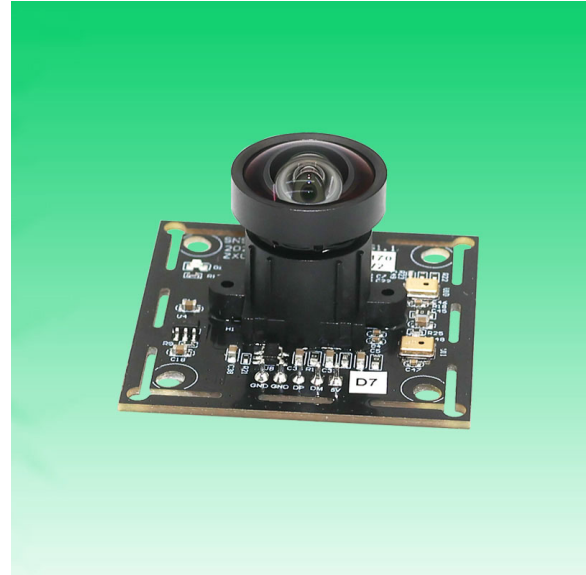

Side View

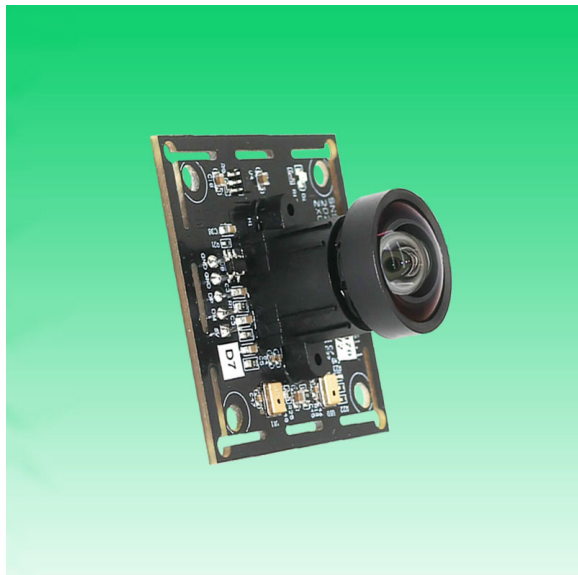

Bottom View



USB Cable

**KLT-USB-1170 V2****16MP 1170 Sony IMX298 M12 Fixed Focus USB 2.0 Camera Module**

| FORMAT | RESOLUTION | FRAME RATE |
|--------|---------------------|------------|
| | | USB 2.0 |
| MJPEG | 640 x 480 (VGA) | 30 FPS |
| | 1280 x 720 (720P) | 30 FPS |
| | 1920 x 1080 (1080P) | 30 FPS |
| | 2592 x 1944 (5MP) | 10 FPS |
| | 3264 x 2448 (8MP) | 10 FPS |
| | 4160 x 3120 (13MP) | 10 FPS |
| | 4656 x 3496 (16MP) | 10 FPS |
| YUV2 | 640 x 480 (VGA) | 30 FPS |
| | 1280 x 720 (720P) | 10 FPS |
| | 1920 x 1080 (1080P) | 2 FPS |



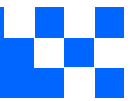

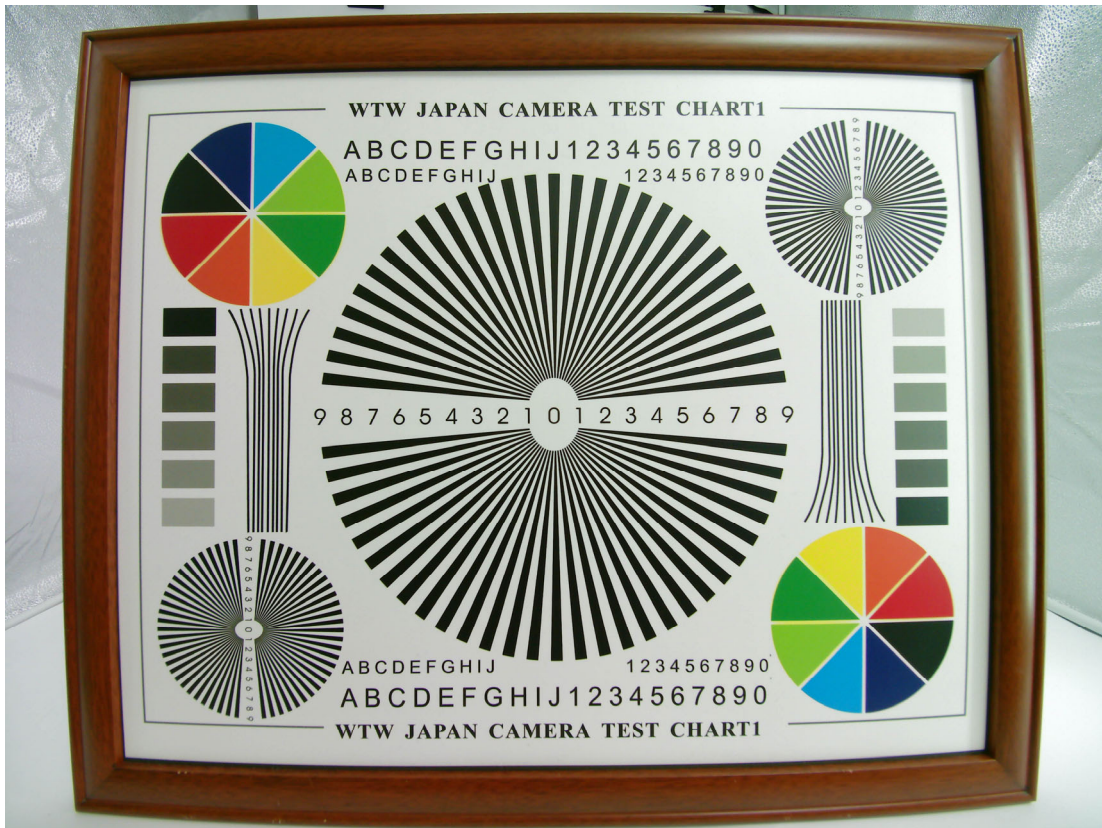

| Version | Information | Date |
|---------|------------------------|-----------|
| V1.0 | First Version | 8-16-2022 |
| V2.0 | Change lens and holder | 6-26-2023 |

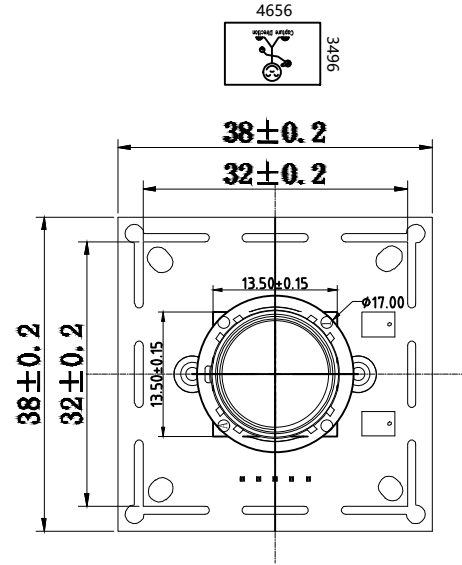

TOP VIEW

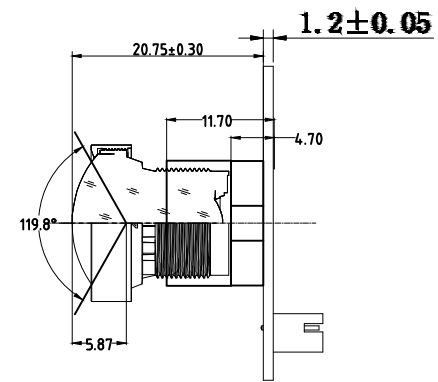

SIDE VIEW

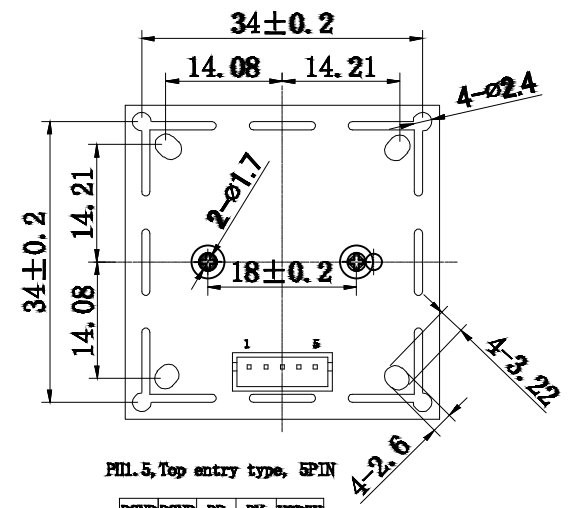

BOTTOM VIEW

Parameters:
1、 Sensor specification:
 Image Sensor: IMX298
 Pixel: 1.12um*1.12um
 Lens Type: 1/2.8
 Important Voltage Description:
 USB 5V (external power supply);

2、 Lens specification:
 FOV: 119.8°(D);105.2°(H);87.2°(V);
 F/NO.: 2.5
 TV distortion: <-3.25%
 Focal length: 2.02mm
 Composition: 2G4P+IR FILTER
 IR Cut Coating: 650nm±10nm@50%

Kai Lap Technologies Group Ltd

| | | | | | |
|-------------|-----------|------------------|-----------------|-----------------|--------|
| Designed By | Kevin | Model Name: | KLT-USB-1170 V2 | | |
| Checked By | Aouly_Yan | Projection Type: | Unit: | Material: ----- | |
| | | | mm | Scale: | Sheet: |
| | | Third Angle | 1:1 | 1 of 1 | 1/0 |

[Product Brief]

Ver.1.0

IMX298

Diagonal 6.521 mm (Type 1/2.8) 16Mega-Pixel CMOS Image Sensor with Square Pixel for Color Cameras

Description

IMX298 is a diagonal 6.521 mm (Type 1/2.8) 16 Mega-pixel CMOS active pixel type stacked image sensor with a square pixel array. It adopts Exmor RS™ technology to achieve high speed image capturing by column parallel A/D converter circuits and high sensitivity and low noise image (comparing with conventional CMOS image sensor) through the backside illuminated imaging pixel structure. R, G, and B pigment primary color mosaic filter is employed. By introducing spatially multiplexed exposure technology, high dynamic range still pictures and movies are achievable. It equips an electronic shutter with variable integration time. It operates with three power supply voltages: analog 2.5 V, digital 1.1 V and 1.8 V for input/output interface and achieves low power consumption.

In addition, this product is designed for use in cellular phone and tablet pc. When using this for another application, Sony does not guarantee the quality and reliability of product. Therefore, don't use this for applications other than cellular phone and tablet pc. Consult your Sony sales representative if you have any questions.

Functions and Features

- ◆ Back-illuminated and stacked CMOS image sensor Exmor RS
- ◆ Phase Detection Auto Focus (PDAF)
- ◆ Single Frame High Dynamic Range (HDR) with equivalent full pixels
- ◆ High signal to noise ratio (SNR)
- ◆ Full resolution @30 frame/s (Normal / HDR). 4K2K @30 frame/s (Normal / HDR) 1080p @60 frame/s (Normal / HDR)
- ◆ Output video format of RAW10/8, COMP8
- ◆ Pixel binning readout and H/V sub-sampling function
- ◆ Advanced Noise Reduction (Chroma noise reduction and RAW noise reduction)
- ◆ Independent flipping and mirroring
- ◆ CSI-2 serial data output (MIPI 2lane/4lane, Max. 1.5 Gbps/lane, D-PHY spec. ver. 1.1 compliant)
- ◆ 2-wire serial communication
- ◆ Two PLLs for independent clock generation for pixel control and data output interface
- ◆ Dynamic Defect Pixel Correction
- ◆ Power-on reset function
- ◆ Dual sensor synchronization operation
- ◆ 9 K bit of OTP ROM for users
- ◆ Built-in temperature sensor

Device Structure

- ◆ CMOS image sensor
- ◆ Image size : Diagonal 6.521 mm (Type 1/2.8)
- ◆ Total number of pixels : 4720 (H) × 3600 (V) approx. 16.99 M pixels
- ◆ Number of effective pixels : 4672 (H) × 3520 (V) approx. 16.44 M pixels
- ◆ Number of active pixels : 4656 (H) × 3496 (V) approx. 16.28 M pixels
- ◆ Chip size : 6.433 mm (H) × 4.921 mm (V)
- ◆ Unit cell size : 1.12 μm (H) × 1.12 μm (V)
- ◆ Substrate material : Silicon

System block diagram

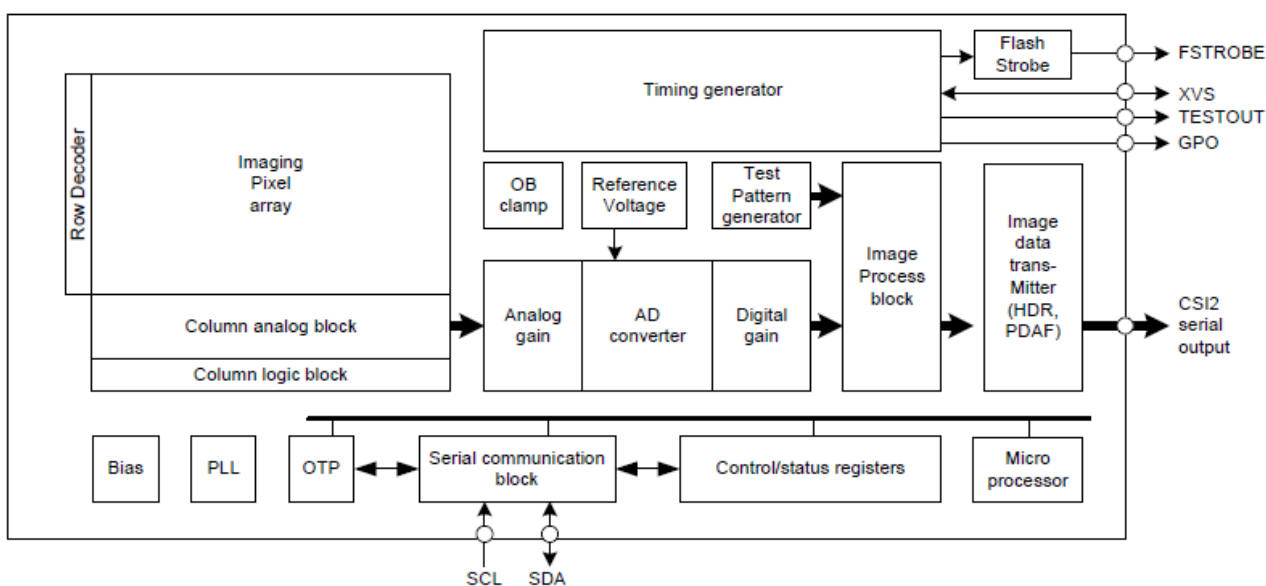

Exmor RS

* Exmor RS is a trademark of Sony Corporation. The Exmor RS is a Sony's CMOS image sensor with high-resolution, high-performance and compact size by replacing a supporting substrate in Exmor R™ which changed fundamental structure of Exmor™ pixel adopted column parallel A/D converter to back-illuminated type, with layered chips formed signal processing circuits.



Cameras Applications



Automotive Driver Pilot



Live Streaming



Video Conference



Eye Tracker Biometric Detection

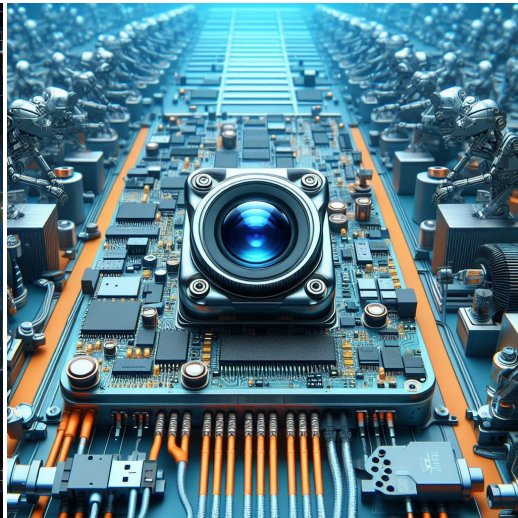

Machine Vision



Agricultural Monitor

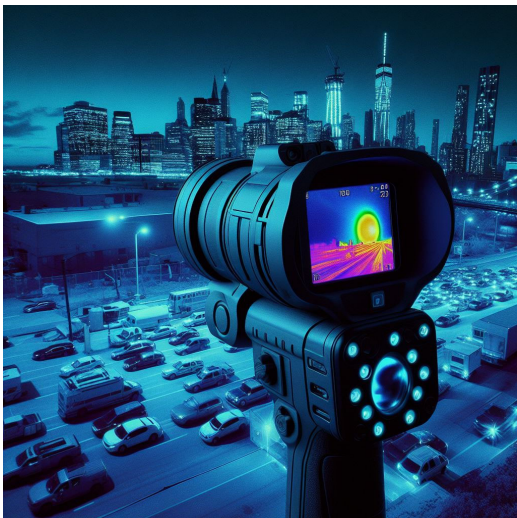

Night Vision Security



Drone and Sports Eagle Eyes



Interactive Pet Camera



your BEST camera module partner

Cameras Applications



IMAGING DEVICES





Camera Module Pinout Definition Reference Chart

| OmniVision | Sony | Samsung | On-Semi | Aptina | Himax | GalaxyCore | PixArt | SmartSens | Sensors |
|-------------------------------|------|---|---------|--------|-------|------------|--------|-----------|---------|
| Pin Signal | | Description | | | | | | | |
| DGND GND | | ground for digital circuit | | | | | | | |
| AGND | | ground for analog circuit | | | | | | | |
| PCLK DCK | | DVP PCLK output | | | | | | | |
| XCLR PWDN XSHUTDOWN STANDBY | | power down active high with internal pull-down resistor | | | | | | | |
| MCLK XVCLK XCLK INCK | | system input clock | | | | | | | |
| RESET RST | | reset active low with internal pull-up resistor | | | | | | | |
| NC NULL | | no connect | | | | | | | |
| SDA SIO_D SIOD | | SCCB data | | | | | | | |
| SCL SIO_C SIOC | | SCCB input clock | | | | | | | |
| VSYNC XVS FSYNC | | DVP VSYNC output | | | | | | | |
| HREF XHS | | DVP HREF output | | | | | | | |
| DOVDD | | power for I/O circuit | | | | | | | |
| AFVDD | | power for VCM circuit | | | | | | | |
| AVDD | | power for analog circuit | | | | | | | |
| DVDD | | power for digital circuit | | | | | | | |
| STROBE FSTROBE | | strobe output | | | | | | | |
| FSIN | | synchronize the VSYNC signal from the other sensor | | | | | | | |
| SID | | SCCB last bit ID input | | | | | | | |
| ILPWM | | mechanical shutter output indicator | | | | | | | |
| FREX | | frame exposure / mechanical shutter | | | | | | | |
| GPIO | | general purpose inputs | | | | | | | |
| SLASEL | | I2C slave address select | | | | | | | |
| AFEN | | CEN chip enable active high on VCM driver IC | | | | | | | |
| MIPI Interface | | | | | | | | | |
| MDN0 DN0 MD0N DATA_N DMO1N | | MIPI 1st data lane negative output | | | | | | | |
| MDP0 DP0 MD0P DATA_P DMO1P | | MIPI 1st data lane positive output | | | | | | | |
| MDN1 DN1 MD1N DATA2_N DMO2N | | MIPI 2nd data lane negative output | | | | | | | |
| MDP1 DP1 MD1P DATA2_P DMO2P | | MIPI 2nd data lane positive output | | | | | | | |
| MDN2 DN2 MD2N DATA3_N DMO3N | | MIPI 3rd data lane negative output | | | | | | | |
| MDP2 DP2 MD2P DATA3_P DMO3P | | MIPI 3rd data lane positive output | | | | | | | |
| MDN3 DN3 MD3N DATA4_N DMO4N | | MIPI 4th data lane negative output | | | | | | | |
| MDP3 DP3 MD3P DATA4_P DMO4P | | MIPI 4th data lane positive output | | | | | | | |
| MCN CLKN CLK_N DCKN | | MIPI clock negative output | | | | | | | |
| MCP CLKP MCP CLK_P DCKN | | MIPI clock positive output | | | | | | | |
| DVP Parallel Interface | | | | | | | | | |
| D0 DO0 Y0 | | DVP data output port 0 | | | | | | | |
| D1 DO1 Y1 | | DVP data output port 1 | | | | | | | |
| D2 DO2 Y2 | | DVP data output port 2 | | | | | | | |
| D3 DO3 Y3 | | DVP data output port 3 | | | | | | | |
| D4 DO4 Y4 | | DVP data output port 4 | | | | | | | |
| D5 DO5 Y5 | | DVP data output port 5 | | | | | | | |
| D6 DO6 Y6 | | DVP data output port 6 | | | | | | | |
| D7 DO7 Y7 | | DVP data output port 7 | | | | | | | |
| D8 DO8 Y8 | | DVP data output port 8 | | | | | | | |
| D9 DO9 Y9 | | DVP data output port 9 | | | | | | | |
| D10 DO10 Y10 | | DVP data output port 10 | | | | | | | |
| D11 DO11 Y11 | | DVP data output port 11 | | | | | | | |



Camera Reliability Test

| Reliability Inspection Item | | Testing Method | Acceptance Criteria | |
|-----------------------------|-----------------------------|---|-------------------------|-------------------------|
| Category | Item | | | |
| Environmental | Storage Temperature | High 60°C 96 Hours | Temperature Chamber | No Abnormal Situation |
| | | Low -20°C 96 Hours | Temperature Chamber | No Abnormal Situation |
| | Operation Temperature | High 60°C 24 Hours | Temperature Chamber | No Abnormal Situation |
| | | Low -20°C 24 Hours | Temperature Chamber | No Abnormal Situation |
| | Humidity | 60°C 80% 24 Hours | Temperature Chamber | No Abnormal Situation |
| | Thermal Shock | High 60°C 0.5 Hours Low -20°C 0.5 Hours Cycling in 24 Hours | Temperature Chamber | No Abnormal Situation |
| Physical | Drop Test (Free Falling) | Without Package 60cm | 10 Times on Wood Floor | Electrically Functional |
| | | With Package 60cm | 10 Times on Wood Floor | Electrically Functional |
| | Vibration Test | 50Hz X-Axis 2mm 30min | Vibration Table | Electrically Functional |
| | | 50Hz Y-Axis 2mm 30min | Vibration Table | Electrically Functional |
| | | 50Hz Z-Axis 2mm 30min | Vibration Table | Electrically Functional |
| | Cable Tensile Strength Test | Loading Weight 4 kg 60 Seconds Cycling in 24 Hours | Tensile Testing Machine | Electrically Functional |
| Electrical | ESD Test | Contact Discharge 2 KV | ESD Testing Machine | Electrically Functional |
| | | Air Discharge 4 KV | ESD Testing Machine | Electrically Functional |
| | Aging Test | On/Off 30 Seconds Cycling in 24 Hours | Power Switch | Electrically Functional |
| | USB Connector | On/Off 250 Times | Plug and Unplug | Electrically Functional |





| Inspection Item | | Inspection Method | Standard of Inspection | | |
|------------------|----------|-------------------|-----------------------------|--|---------------------------------|
| Category | Item | | | | |
| Appearance | FPC/ PCB | Color | The Naked Eye | Major Difference is Not Allowed. | |
| | | Be Torn/Chopped | The Naked Eye | Copper Crack Exposure is Not Allowed. | |
| | | Marking | The Naked Eye | Clear, Recognizable (Within 30cm Distance) | |
| | Holder | Scratches | The Naked Eye | The Inside Crack Exposure is Not Allowed | |
| | | Gap | The Naked Eye | Meet the Height Standard | |
| | | Screw | The Naked Eye | Make Sure Screws Are Presented (If Any) | |
| | | Damage | The Naked Eye | The Inside Crack Exposure is Not Allowed | |
| | Lens | Scratch | The Naked Eye | No Effect On Resolution Standard | |
| | | Contamination | The Naked Eye | No Effect On Resolution Standard | |
| | | Oil Film | The Naked Eye | No Effect On Resolution Standard | |
| | | Cover Tape | The Naked Eye | No Issue On Appearance. | |
| | Function | Image | No Communication | Test Board | Not Allowed |
| | | | Bright Pixel | Black Board | Not Allowed In the Image Center |
| Dark Pixel | | | White board | Not Allowed In the Image Center | |
| Blurry | | | The Naked Eye | Not Allowed | |
| No Image | | | The Naked Eye | Not Allowed | |
| Vertical Line | | | The Naked Eye | Not Allowed | |
| Horizontal Line | | | The Naked Eye | Not Allowed | |
| Light Leakage | | | The Naked Eye | Not Allowed | |
| Blinking Image | | | The Naked Eye | Not Allowed | |
| Bruise | | | Inspection Jig | Not Allowed | |
| Resolution | | | Chart | Follows Outgoing Inspection Chart Standard | |
| Color | | | The Naked Eye | No Issue | |
| Noise | | | The Naked Eye | Not Allowed | |
| Corner Dark | | | The Naked Eye | Less Than 100px By 100px | |
| Color Resolution | | | The Naked Eye | No Issue | |
| Dimension | Height | The Naked Eye | Follows Approval Data Sheet | | |
| | Width | The Naked Eye | Follows Approval Data Sheet | | |
| | Length | The Naked Eye | Follows Approval Data Sheet | | |
| | Overall | The Naked Eye | Follows Approval Data Sheet | | |



KLT Package Solutions

KLT Camera Module



Complete with Lens Protection Film



Tray with Grid and Space



Place Cameras on the Tray





Camera Modules Package Solution

Full Tray of Cameras



Cover Tray with Lid



Put Tray into Anti-Static Bag



Vacuum the Anti-Static Bag

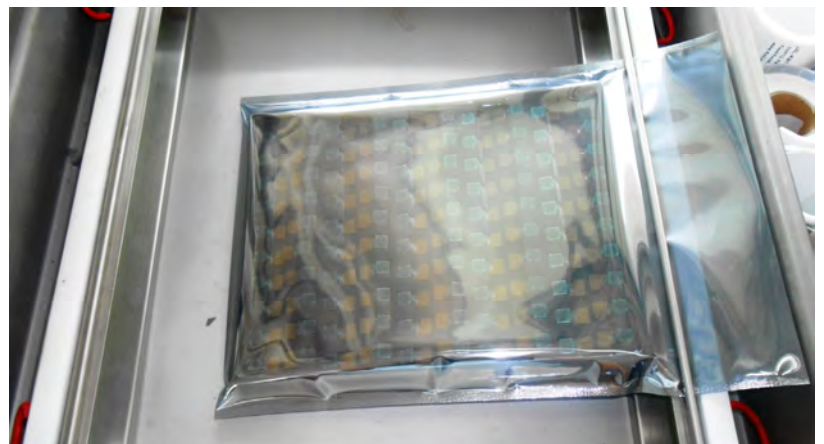



Camera Modules Package Solution

Sealed Vacuum Bag with Labels

1. Model and Description 2. Quantity 3. Shipping Date 4. Caution





Large Order Package Solution

Place Foam Sheets Between Trays



Foam Sheets are Slightly Larger than Trays



Place Foam Sheets and Trays into Box



Foam Sheets are Tightly Fitting Box





Small Order Package Solution

Place Foam Sheets and Trays into Small Box



Foam Sheets are Nicely Fitting the Small Box



Package in Small Box for Shipment



Place Small Boxes into Larger Box





your BEST camera module partner

Carbon Box Package Solution

Seal the Carbon Box

Final Package Labelled Box



Carbon Box Ready for Shipment

1. Delivery Address and Phone No. 2. Box No. and Ship Date 3. Fragile Caution





Sample Order Package Solution

Place Sample into Small Anti-Static Bag



Place Connectors into Small Ant-Static Bag



Sample Labels on the Small Bag

1. Camera Module or Connector Model 2. Shipping Date and Quantity 3. Caution





Connectors Large Order Package Solution

Connectors in a Wheel



Label Connectors in the Wheel



The Wheel is Perfectly Fitting the Box



Connectors Box Ready for Shipment





your BEST camera module partner

Company Kai Lap Technologies (KLT)

Kai Lap Technologies Group Limited. (KLT) was established in 2009, a next-generation technology driven manufacturer specialized in research, design, and produce of audio and video products. KLT is occupying 20,000 square feet automated plants with 100 employees of annual throughput 30,000,000 units cameras.

KLT provides OEM, ODM design, contract manufacturing, and builds the camera products. You may provide the requirements to us, even with a hand draft, our sales and engineering work together to meet your needs. We consider ourselves your last-term partner in developing practical and innovative solutions.

Our team covers everything from initial concept development to mass produced product. KLT specializes in customized camera design, raw material, electronic engineering, firmware/software development, product testing, and packing design. Our experienced strategic supply systems offer a robust and dependable manufacturing capacity for orders of various sizes.

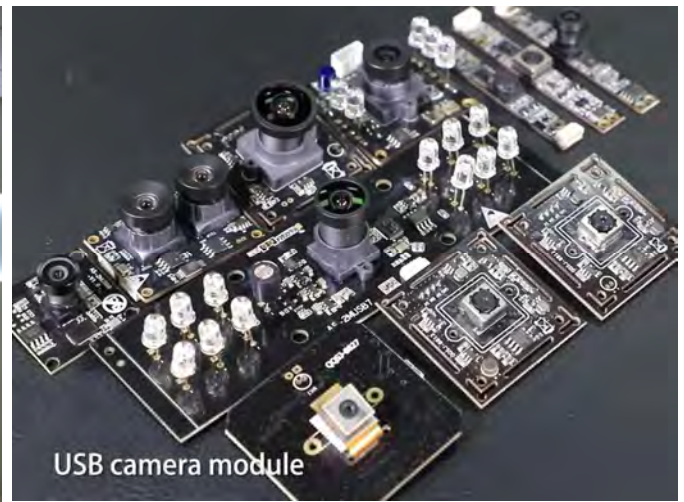

Limited Warranty

KLT provides the following limited warranty if you purchased the Product(s) directly from KLT company or from KLT's website, www.KaiLapTech.com. Product(s) purchased from other sellers or sources are not covered by this Limited Warranty. KLT guarantees that the Product(s) will be free from defects in materials and workmanship under normal use for a period of one (1) year from the date you receive the product ("Warranty Period").

For all Product(s) that contain or develop material defects in materials or workmanship during the Warranty Period, KLT will, at its sole option, either: (i) repair the Product(s); (ii) replace the Product(s) with a new or refurbished Product(s) (replacement Product(s) being of identical model or functional equivalent); or (iii) provide you a refund of the price you paid for the Product(s).

This Limited Warranty of KLT is solely limited to repair and/or replacement on the terms set forth above. KLT is not reliable or responsible for any subsequent events.





CMOS CAMERA MODULES



your BEST camera module partner

KLT Strength

Powerful Factory



Professional Service



Promised Delivery



www.KaiLapTech.com sales@KaiLapTech.com Tel: (852) 6908 1256 Fax: (852) 3017 6778

All rights reserved @ Kai Lap Technologies Group Ltd. Specifications subject to change without notice.